

One Piece Shower Module Cast Acrylic

FEATURES

- **A 6030.01GU**

The unit is molded with a shampoo/soap shelf along the back wall. All units have an anti-skid floor treatment.

The unit shall be installed in a pit, $\frac{7}{8}$ " (22) deep so that the finished floor will be level with the top of the threshold.

Unit must be set in a mortar base leveled and any clearances between the pit opening and the unit be filled with mortar. It is recommended that a floor drain be located near the entrance to the shower.

The factory supplied components are to include three stainless steel horizontal grab bars, two additional molded shampoo shelves in each corner, and a stainless steel curtain rod.

The unit is thermoformed from a solid color Lucite XL® high gloss acrylic sheet into a one piece, totally seamless unit. This unit is reinforced on the back with a composite matrix which has a backside fire rating of "A" and a flame spread of 25. The shower models are pre-drilled to accept a 2" (51) shower drain (supplied by others).

- **A 6030.01GU.3**

Same as above in 3-piece

NOTES

- The shower units shall conform to ANSI A-117.1 and ANSI Z-124.2; the shower shall also comply with the guidelines issued by ADA, US. Architectural and Transportation Barriers Compliance Board (A & T.B.C.B.) and with most city, state, and national standards for barrier free, accessible shower facilities for the handicapped.
- Nominal Dimensions: Inside: 60" x 30" (1524 x 762)
Outside: 68 $\frac{3}{4}$ " x 33 $\frac{1}{4}$ " (1746 x 845)
Pit Roughing-In: 69 $\frac{1}{4}$ " x 33 $\frac{1}{2}$ " (1759 x 851)
- Factory installed components are provided with additional back reinforcements to provide code complying structural integrity and are sealed from the backside.

OPTIONS

- Dome Light. (1001/1021)
- Shower Curtain. (C7)
- 2" (51) plastic drain with chrome plated strainer. (PD2)
- 2" (51) cast brass drain with chrome plated strainer. (H30)
- Lucite® acrylic sheet containing Microban® antimicrobial product protection. Available in white and bone only. (MBP)

Lucite is a registered trademark of INEOS Acrylics, Inc. Microban is a registered trademark of Microban Products Company, Huntersville, NC.

One Piece Acrylic Shower Modules

A 6030.01GU

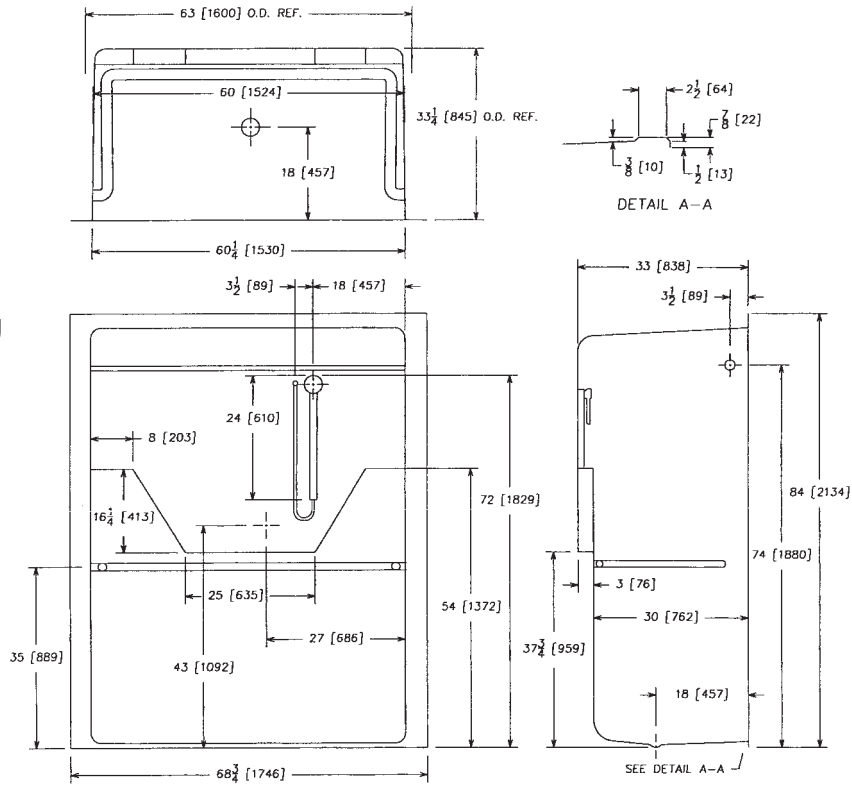

A 6030.01GU.3

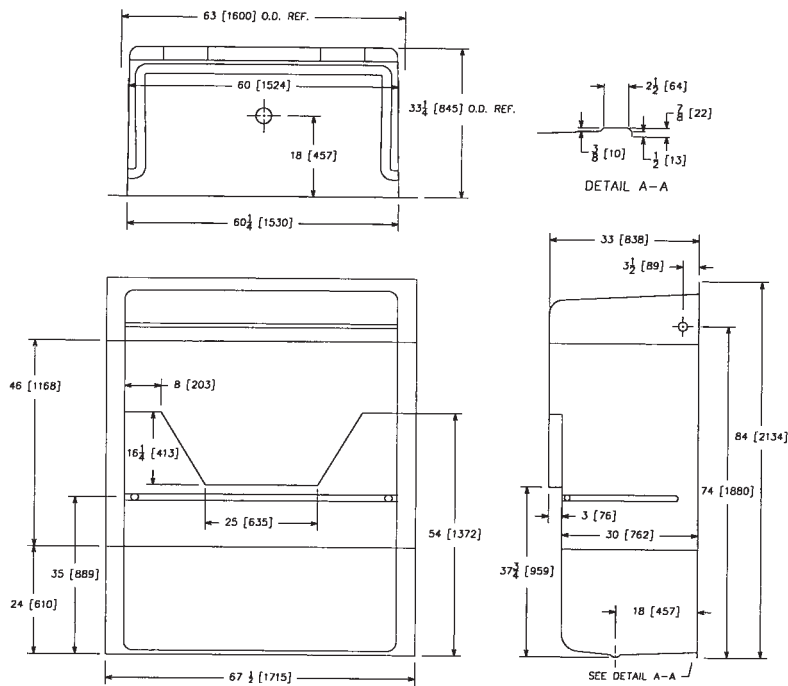

IMPORTANT: Roughing-in dimensions may vary 1/2" and are subject to change or cancellation without prior notice. No responsibility is assumed for use of superseded or voided leaflets.