

MCS-338 DOME INSTALLATION

Carefully remove the dome from its box and remove the protective foam wrap. The dome is supplied with a chrome or gold J-molding to match your door finish. The J-molding has double sided acrylic transfer adhesive applied to its back side which is used to mount the J-molding to the MCS-338 acrylic corner unit.

You will notice that the top rail channel on the SD-39 door is notched (where it meets the walls) to accommodate the dome. Similarly, the J-molding has several small cuts to allow it to conform to the back corner of the unit and the radius of the dome.

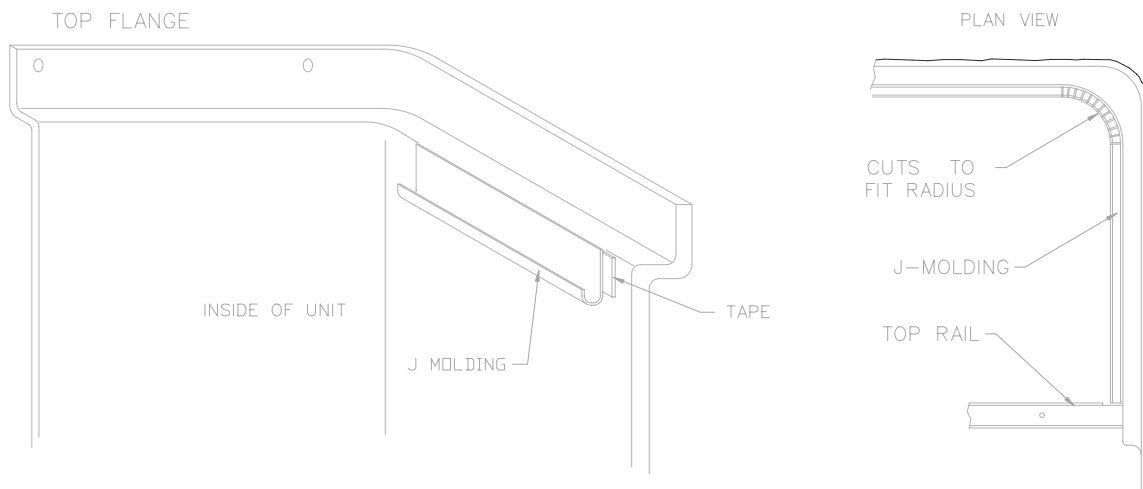

The above illustration shows where the J-molding must be installed: It must be flush with the edge of the top flange recess. It is recommended to position and mark the location of the J-molding then removing the release liner and securing the J-molding in place by pressing it firmly against the wall.

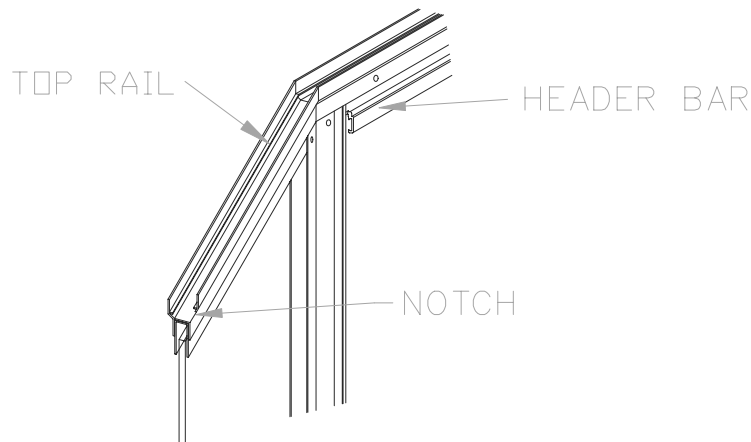

Apply a bead of silicone inside the J-molding and top rail channels to secure and seal the dome in place.

Now place the dome in the J-molding and the top rail channel of the door. Make sure it is properly set in its track by pressing down lightly on the dome's outer edges. Allow 1 hour for silicone to set.